

TRITHON

WITH Awax safety module

ELECTRONIC CODED NON-CONTACT SAFETY SWITCH ADAPTED TO HIGH TEMPERATURE

- Decoding by Acotom®2 process
- Misalignment : ±30° in rotation
- Detection distance /hysteresis : 9 /+2 (mm)
- Moulded cable
- Auxiliary output for automation control or lights
- Stainless steel 316L housing
- Laser marking
- Protection class IP69K
- Temperature -20°C to +110°C
- Unlimited life expectancy (unlimited number of operations)



SAFETY CATEGORY

Trithon : EN60947-5-3

1 Trithon with Awax : category 4

Trithon in series with Awax : category 3

WIRING DIAGRAM

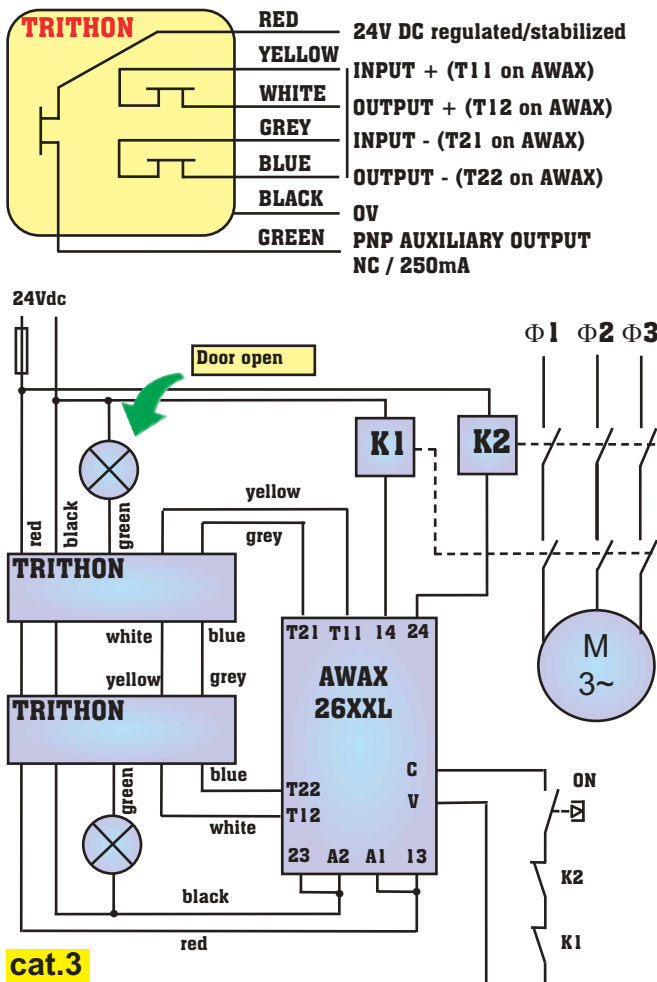

DIMENSIONS

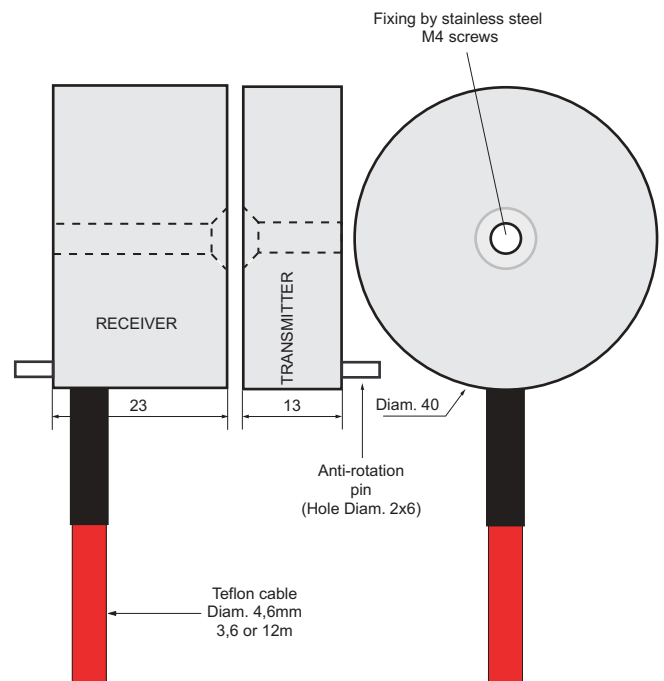

ADVICE

Up to 30 switches with one AWAX module. Adapted to high temperatures (sterilisation), laser markings. Resists to chlorine and acids, may get in touch directly with dairy products.